



Advantage Rectangular Refrigerated Cheese-Deli Island Merchandiser

ACI-2-6000



Features and Benefits

- Remote refrigeration
- Copper tubing and aluminum fin coil construction
- Solid steel base construction
- 3mm sentra deck pan design for easy access to 115v. fan motors and drain
- Adjustable 12" powder coated lighted shelving with product retainer and price tag molding
- Allows for multi-merchandising configurations
- 18" top shelf with vinyl tee-edging
- 12" tempered 3/8" perimeter fence for added case performance
- 9" tempered 1/4" glass product stops
- Solar digital thermometer
- Stainless steel or powder coated handrail trim
- 2" cart bumper

Options

- Handrail height variations
- 1", 2", or 3" cart bumper with various color options
- Wood or powder coated body cladding
- Stainless steel interior or powder coated high-gloss black or white
- High pressure laminate body or metal cladding
- Top shelf available in custom widths
- Top shelf lighting
- 3/8" perimeter acrylic fence
- 1/4" product stops
- Standard lengths: 8', 12', (longer lengths available)

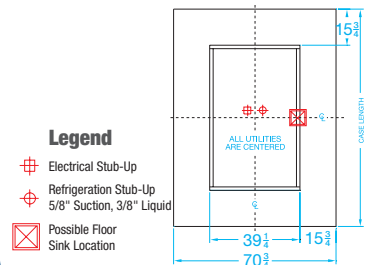
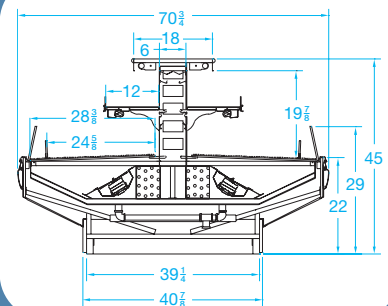

Legend

- Electrical Stub-Up
- Refrigeration Stub-Up
- 5/8" Suction, 3/8" Liquid
- Possible Floor Sink Location

