

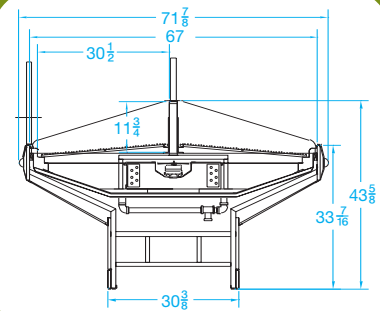

# Refrigerated Produce Island Merchandiser ARP600

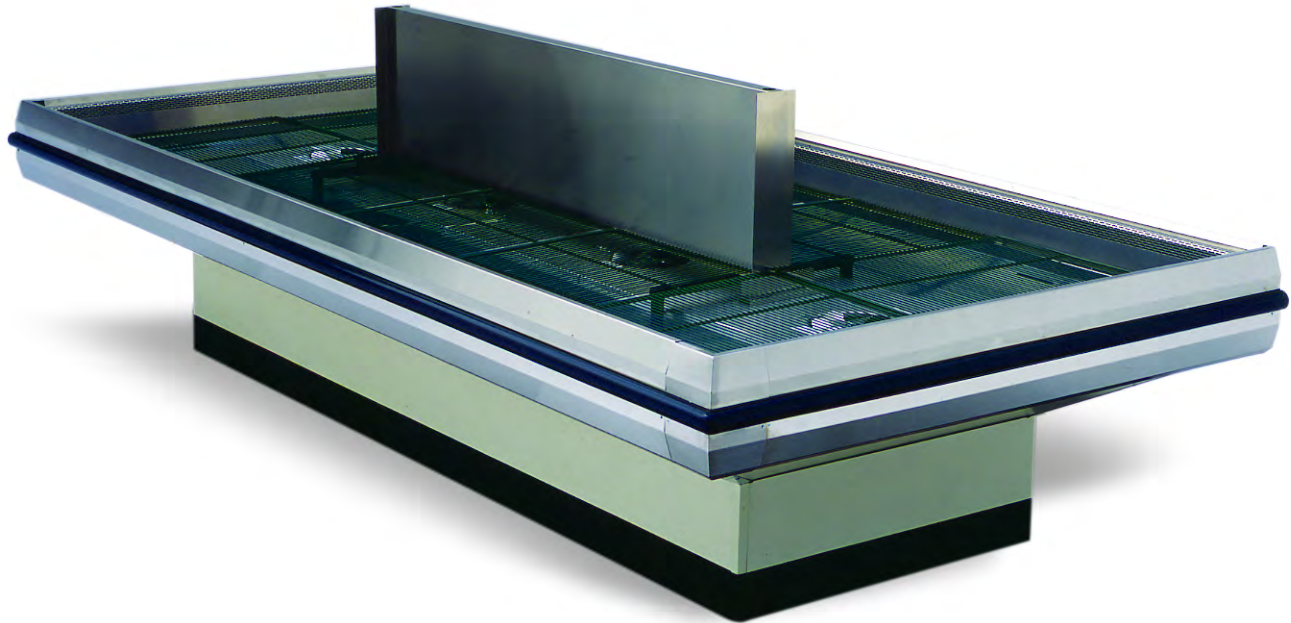

## Features and Benefits

- Remote refrigeration
- Copper tubing and aluminum fin coil construction
- Solid steel base construction
- Galvanized steel deck pan allows easy access for service
- Adjustable powder coated flat wire shelving allows for multi-merchandising configurations
- Stainless steel center riser 2" wide x 12" tall
- Solar digital thermometer
- Stainless steel handrail trim
- 2" cart bumper

## Options

- Handrail height variations
- 1", 2", or 3" cart bumper with various color options
- Optional wood or powder coated body cladding
- Interior powder coated high-gloss black or white
- Plexiglass or wire product fence
- Vertical bag rollers
- Center riser mounted price wire assemblies
- Standard lengths: 8', 10', 12', 14', 16', 18', 20', 22' (2pcs), 24' (2pcs), 26' (2pcs), and 28' (2pcs)

