

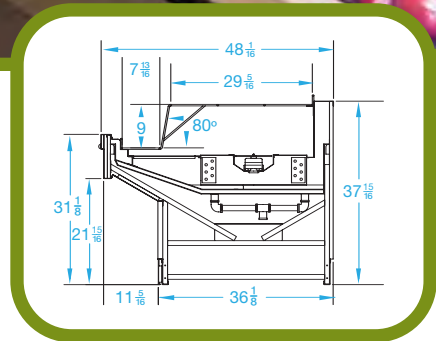

Refrigerated Single Deck Produce Merchandiser ARP400



Features and Benefits

Metal or high-pressure laminated lower & upper body that offers an esthetically pleasing appearance as well as customer accessibility to merchandise.

Body profile allows for additional perimeter base product display

Stainless Steel rear riser offers support for wire racks, additional product merchandizing, and definitive separation of product

Flat wire racks

Stainless steel exterior cladding

Perimeter Bumper offers esthetic protection to case exterior.

Energy Saving fan motors

Options

Available in various depths and lengths

2 or 3 stepped wire product hump racks/shelves

Various riser heights

Various handrail heights

Bag roller dispenser

Scale hangers

Top Shelf: available in custom widths and lighting options

Exterior trim options available to match customer specifications

Energy saving fan motors

Custom body & cladding colors: high quality powder coating

Bumper colors and sizes 1", 2", and 3" widths

Non Refrigerated dry deck applications

LED lighting

